

# V-Cleat Road-Away Milling Belt

High capacity cleat designs  
for ultimate performance  
and durability

**APACHE**

HOSE & BELTING CO., INC.



[www.road-awaybelt.com](http://www.road-awaybelt.com)

# Features and Benefits that Make Apache's High Performance V-Cleat Patterns Superior

- High strength rubber compounds allow belt and cleats to withstand Impact from heavy, sharp materials.
- Our single piece / molded cleats eliminate the danger of cleat separation from the belt.
- Advanced splicing techniques assure ultimate strength, flexibility and performance to withstand the rigors of high speeds and small pulley diameters.
- More carrying capacity and better leveling of material on carrying side.
- Smoother, quieter return and better tracking, thanks to the center "Stabilization Profile."
- 1" high cleats for ultimate capacity.
- Wide cleat base for added strength and durability.

Mechanical fasteners are also available. Apache recommends Flexco 550 Bolt Hinged Megalloy Fasteners with bare stainless pin.

## V-Cleat Road-Away Milling Belt

is available in three belt constructions:

- 2 Ply 220# piw with 3/16" top cover x 1/16" bottom cover Gauge: .375' with cleat 1.375"
- 2 Ply 400# piw with 3/16" top cover x 1/16" bottom cover Gauge: .394' with cleat 1.394"
- 3 Ply 225# piw with 3/16" top cover x 1/16" bottom cover Gauge: .420' with cleat 1.420"

PIW=Pounds per inch of belt width per lineal foot.



# V-Cleat Patterns

12" Cleat centers  
Metric widths available

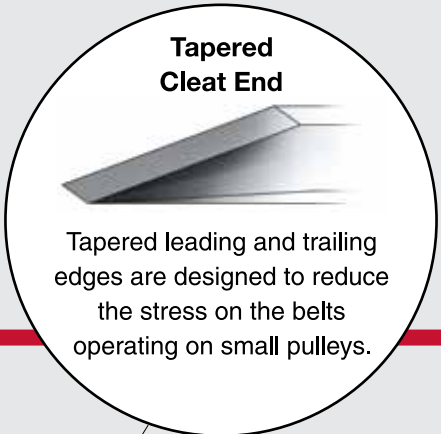

## NEW Pattern!

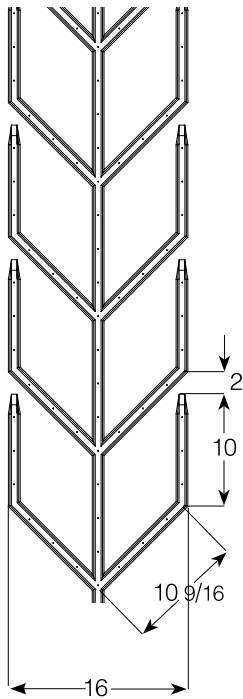

- 24" Belt width **MAXIMUM**
- 1/2" Cleat height
- 1-3/16" Cleat base width
- 1/2" high "continuous" stabilizing center profile
- Base belt recommended is 2 ply 220# 3/16 x 1/16 for smaller pulleys

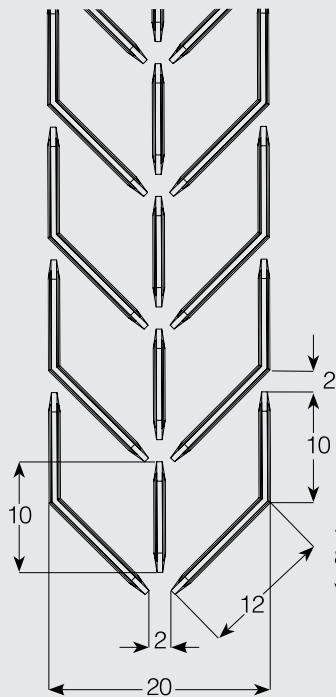

- 30" Belt width minimum
- 1" Cleat height
- 1-1/4" Cleat base width
- 1" high "continuous" stabilizing center profile

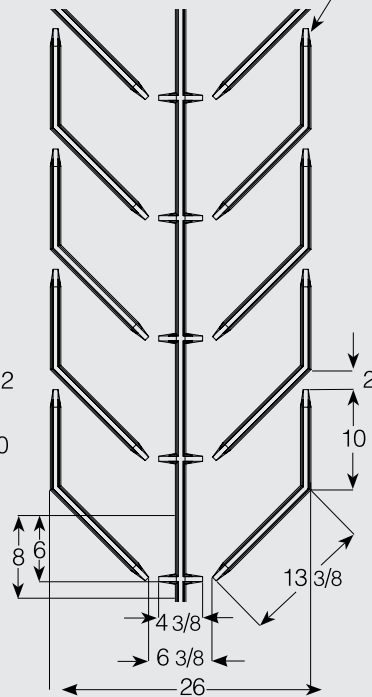

- 36" Belt width minimum
- 1" Cleat height
- 1-1/4" Cleat base width
- 1" high "continuous" stabilizing center profile

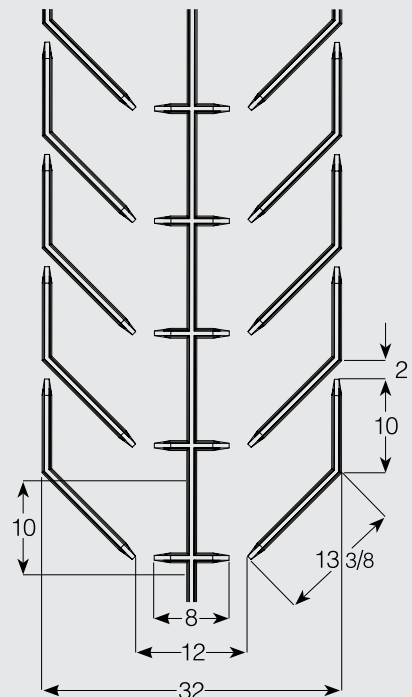

- 42" Belt width minimum
- 1" Cleat height
- 1-1/4" Cleat base width
- 1" high "continuous" stabilizing center profile

# Molded U-Cleat Road-Away Milling Belt

## 20" cleat pattern

24" belt widths, minimum

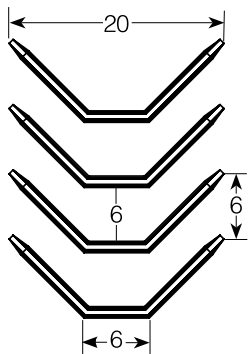

## 26" cleat pattern

36" belt widths, minimum

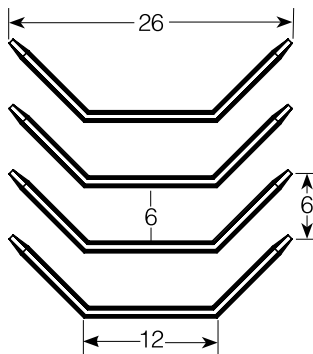

## 30" cleat pattern

42" belt widths, minimum

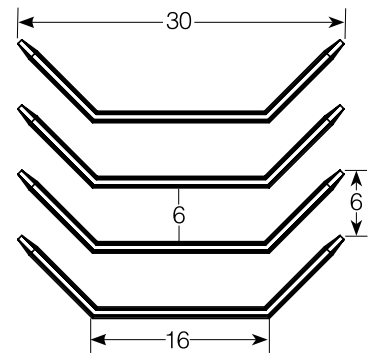

# Vulcanized Custom Cleated Belt Patterns for Milling and Other Applications

## OTHER CUSTOM PATTERNS AVAILABLE

### DUROCLEAT™ Molded Chevron

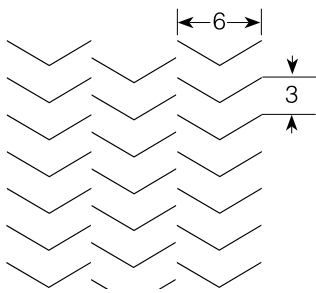

Cleats: 1/4" High x 3/8" wide

### Steep Angle Chevrons

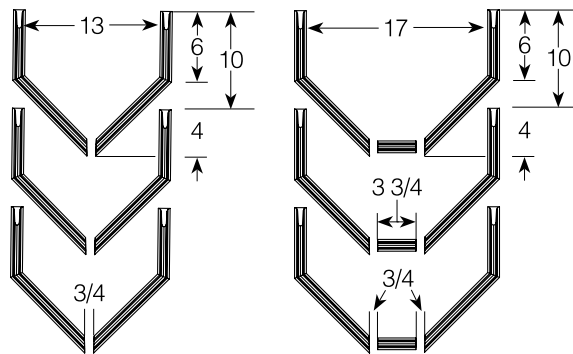

Cleats: 1 1/2" High x 3/4" wide

### Closed Chevrons

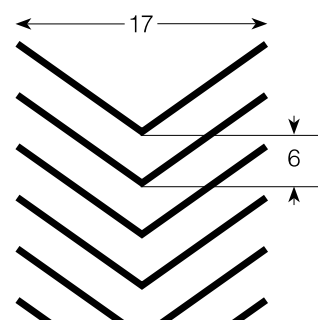

Cleats: 3/8" High x 3/8" wide

### CORPORATE HEADQUARTERS

CEDAR RAPIDS, IA

ISO 9001:2008 Certified  
Website: [www.apachehb.com](http://www.apachehb.com)

NATIONAL SALES GROUP  
Toll Free: 800-553-5455  
Fax: 319-365-2522

### REGIONAL SALES AND DISTRIBUTION CENTERS

CEDAR RAPIDS, IA  
Toll Free: 800-332-3243

MINNEAPOLIS, MN  
Toll Free: 800-328-4149

N. KANSAS CITY, MO  
Toll Free: 800-821-5160

CHICAGO, IL  
Toll Free: 800-635-4712

### WARRANTY

All merchandise designed, manufactured or assembled by Apache is warranted at the time of shipment to be free from defects in the original design, material and manufacture, provided such merchandise is properly installed and used only for the intended purpose and under normal service conditions. Liability with respect to any such merchandise proved defective is limited to buyer's net purchase price or, at Apache's option, the repair or replacement thereof upon its return to Apache freight prepaid. In no event shall Apache be liable to supply or pay for labor, downtime, or any loss or damage, either direct, incidental or consequential. All merchandise supplied by Apache but designed, manufactured and assembled by others shall be accepted by Buyer with only those warranties made by such vendors or manufacturers and in lieu of any additional warranties on the part of Apache.

THIS WARRANTY IS EXPRESSLY MADE IN LIEU OF ANY AND ALL OTHER WARRANTIES, INCLUDING THE WARRANTY OF MERCHANTABILITY AND FITNESS FOR A PARTICULAR PURPOSE.

99002332-V / AP-9A / rev071509

100% EMPLOYEE OWNED



PROUD MEMBER OF



**FOR MORE INFORMATION ON  
THESE AND OTHER PRODUCTS  
CALL TOLL FREE:  
1-800-553-5455**

**APACHE**  
HOSE & BELTING CO., INC.